

Mast Boom

Snorkel



- Working height up to 32ft.
- Working outreach to 9ft. 9in.
- Platform capacity for 2 people and tools
- 138° articulating jib
- 360° mast rotation
- One-hand proportional controls
- M2032J just 32in. wide
- 12in. inside turning radius
- Driveable while fully elevated
- Non-marking tires

M2032J

M2639J

M2032/2639J mast boom specifications

	M2032J	M2639J
max. working height	25ft.8in.	32ft.3in.
max. platform height	19ft.8in.	26ft.3in.
max. drive height	19ft.8in.	26ft.3in.
max. working outreach	8ft.7in.	9ft.9in.
platform capacity (SWL)	475lb.	475lb.
platform size	31in. x 29in.	31in. x 29in.
width A	32in.	39in.
stowed height B	6ft.5in.	6ft.5in.
stowed length C	8ft.0in.	9ft.4in.
gross weight	6,675lb.	7,000lb.
drive speed - stowed	1.9mph.	1.9mph.
- elevated	0.43mph.	0.43mph.
gradeability	14° / 25%	14° / 25%
inside turning radius	12in.	12in.
outside turning radius	6ft. 1in.	6ft. 10in.
jib arc	138°	138°
mast rotation	360° (non-continuous)	
control system	smooth, one-hand proportional controls	
power source	4 x 6V x 375 AH batteries	

DANGER: Models described in this brochure are NON-INSULATED and do not provide electrocution protection from contact with or close proximity to energized conductors which is pointed out on decals and placards attached to the machine. Only qualified and trained operators are to be authorized to use and operate a work platform. Aerial work platforms must be elevated only on firm, level surface. Products in this brochure comply with applicable ANSI Standards. This literature is for illustrative purposes only. Consult Operating Maintenance and Parts Manuals for proper procedures. Specifications may vary and are subject to change without notice or obligation.

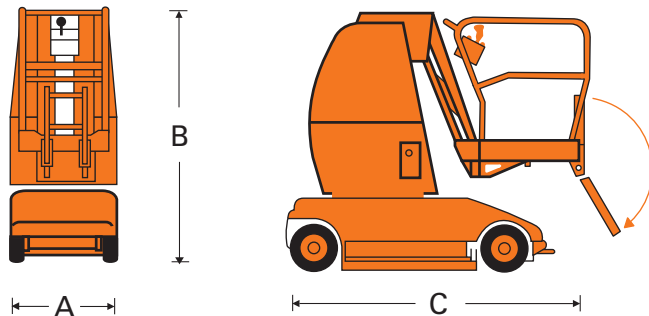

BP1 - M2032/2639J USA 12/07

standard features

- Proportional one-hand controls
- Ultra-tight inside turning radius
- Tilt alarm
- Two person basket
- Solid non-marking tires
- Ground control station
- Self-seeking automatic charger with line contactor allowing AC/DC operation
- Automatic battery top up
- 1 year parts and labor warranty
- 5 years structural warranty

options

- Flashing amber beacon
- Power to platform (220V or 110V)
- Special paint colors
- Environmental green oil

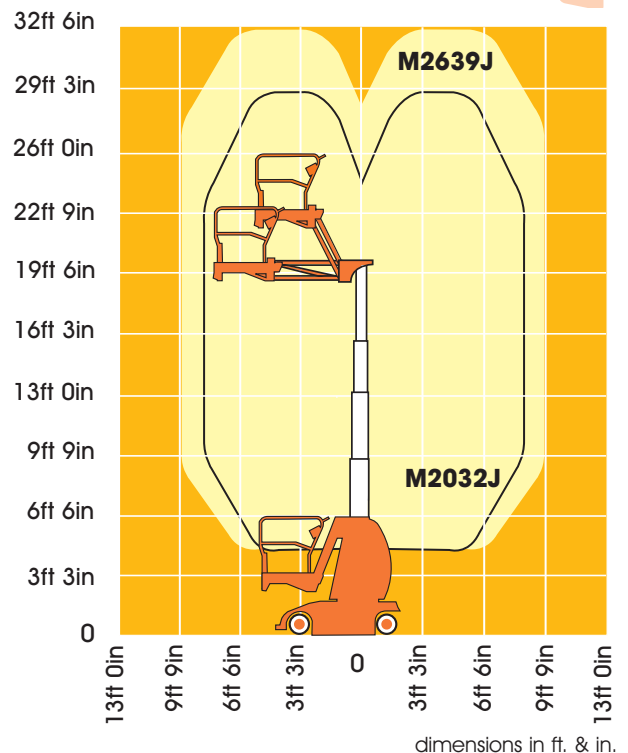

dimensions in ft. & in.

Meets or exceeds applicable requirements of OSHA, ANSI A92.6 and CSA B354.1-04

CE This product is available with the CE mark confirming compliance with all relevant European Machinery Directives

manufactured by
Snorkel
INTERNATIONAL

Snorkel PO Box 1160, St. Joseph, MO 64502-1160, USA
Tel: +1 (785) 989-3000 Toll Free: +1 (800) 255-0317
Sales fax: +1 (785) 989-3070 Parts fax: +1 (785) 989-3077
www.snorkelusa.com